



Cert. n° 0545



[www.eurovent-certification.com](http://www.eurovent-certification.com)

Compliant  
with UE 1253/14  
Regulation



Air Conditioning  
Titan Air Handling Units



**SABIANA**  
IL CLIMA AMICO



IL CLIMA AMICO



The **Titan** air handling units are built in compliance with the European standards and directives, they are certified by EUROVENT and can be selected with performance that complies with European EU Regulation 1253/2014 (Ecodesign directive).

They are specifically designed to satisfy all design requirements of air conditioning systems in which the reduction of noise levels, high air quality and minimum energy consumption are fundamental aspects during the assessment.

The main defining feature of this new series concerns the special design of the **aluminium profiles** that make up the structure, designed to create a perfectly smooth internal surface, without gaps or protrusions, so as to simplify cleaning and allow the components to be extracted from the side.

**External plate sandwich panels, 50 mm** thick, with the inside and outside surface made of different materials: galvanised steel, pre-painted galvanised steel, Peraluman or stainless steel with interposed high density polyurethane foam or mineral wool thermal insulation that can guarantee maximum safety in case of fire (no toxic gases are released), with effective sound absorption.

The constructional versatility and the wide range of components allow technical and dimensional solutions that can respond to any need. The systems are available as packaged units or a series of modular components, in a horizontal arrangement, with two overlying levels, and also in a vertical or side by side one.

The structure of the **base**, made from thick galvanised sheet metal profiles or aluminum extruded profiles, guarantees maximum stability and uniform weight distribution.

**Centrifugal fans** are normally used in all versions: with forward and backward curved blades or **plug fans**. The electric motors are Unel Mec with energy efficiency class IE3, suitable also to be used with an inverter board, or electronic (brushless) ones, that are equipped with a own controller.

The **heat exchange coil** can be built to handle different heat carrier fluids, such as: hot, superheated or chilled water, steam, ethylene glycol mixes, halogenated refrigerants, etc., or alternatively can be electrically powered.

Particular attention was paid to the quality and purity of the air by providing **electrostatic filters** derived from our Crystall patented range in addition to the entire range of mechanical filters on the market, and the UV **germicidal tubes** fitted on a coil for localised treatments or into tunnels.

The static or rotary **heat exchangers** and the water or steam humidifiers, as well as all other components are selected or designed according to the latest technologies.

The extensive range of performance, the vast availability of components and accessories, the multiple constructional variants featured for both the standard and custom configurations, and the high quality of the materials used make this series of units, in terms of value-for-money, some of the most reasonably priced and appealing on the market.

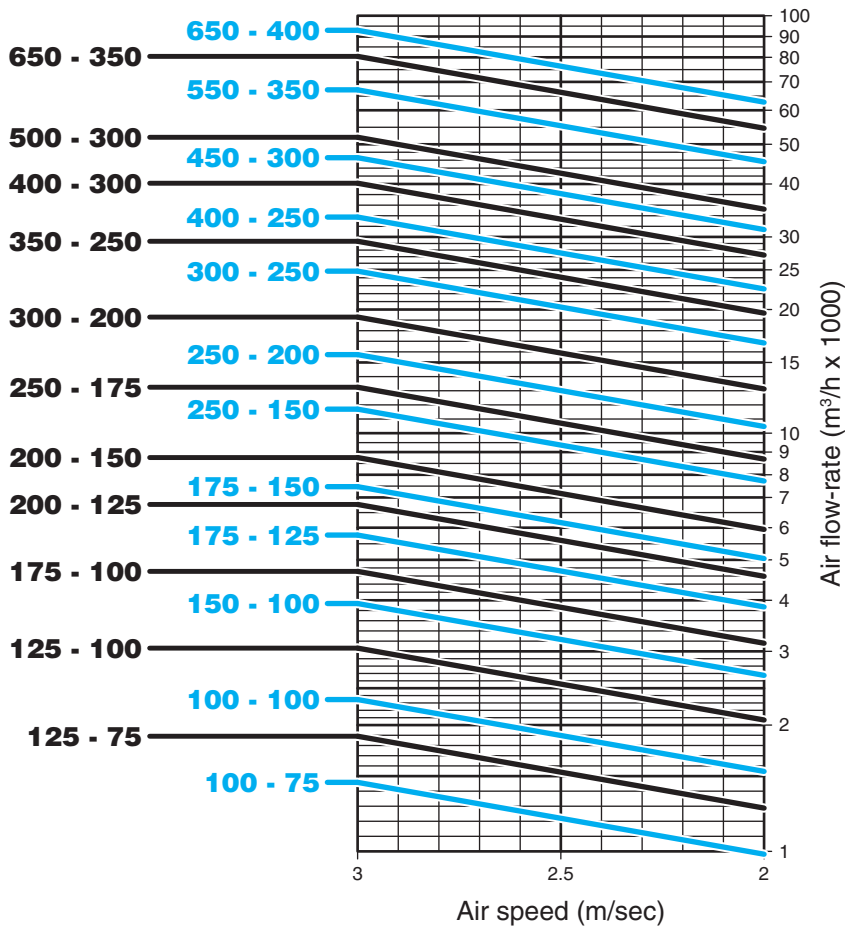

The **Titan** air handling units are available in **23 sizes** that can be easily selected using the diagram shown on the side, based on the air speed through the coil.

To simplify selection, it must be stressed that in both cooling/dehumidification and heating/humidification, the correct air speed is essential to avoid entraining drops.

It is therefore recommended to use a droplet separator for humidification and dehumidification when the air speed exceeds 2.5 m/sec. In humidification and cooling/dehumidification, the maximum speed of 2.8 m/sec should not be exceeded.

## Selection software

**SABIANA** has developed software for selecting and quoting the **Titan** air handling units, containing all the functions for choosing, calculating and sizing the components.

This tool allows the system to be configured and sized based on the design requirements, and analyses the performance in a simple and intuitive manner.

Once having chosen the model, all the components selected are automatically sized; the units can be selected with an in-line, stacked or vertical arrangement.

By choosing the materials and based on the configuration, the program can provide an immediate quotation (Ecodesign conformity), saving and printing the report if needed.

**SABIANA's** extensive experience with these types of units has allowed the creation of templates with numerous configurations, including the most common ones that can be used as the basis for quickly configuring a design and quotation.



The casing of the Titan units is made up as follows:

- **supporting frame** made from extruded aluminium alloy section bars, natural colour.
- **joints** made of die-cast aluminium
- **sandwich panels, 50 mm thick**, made from the following materials:
  - **standard:** *outer:* pre-painted galvanised steel, light grey colour, C21.  
*inner:* galvanised steel  
*insulation:* injected polyurethane, density 45 Kg/m<sup>3</sup>
  - **upon request:** *outer and inner:*  
galvanised steel  
pre-painted galvanised steel  
AISI 304 stainless steel  
peralluman.  
*insulation:* mineral wool, density 90 Kg/m<sup>3</sup>.
  - **assembly:** using galvanised steel self-threading screws, with Neoprene self-adhesive gaskets inserted between the sections and the panels.  
All the screws are in bushes.
- **access doors:** same construction as the panels, fitted with reinforced hinges and locking device, complete with sealing gasket, safety switch for fan sections and, upon request, fitted with inspection window.
- **base frame:** made of C-shaped thick galvanised steel sheet metal or aluminium extruded profiles, secured to the base profiles of the individual modular sections and having perimeter holes to engage the lifting device.

Detail “joint profile”

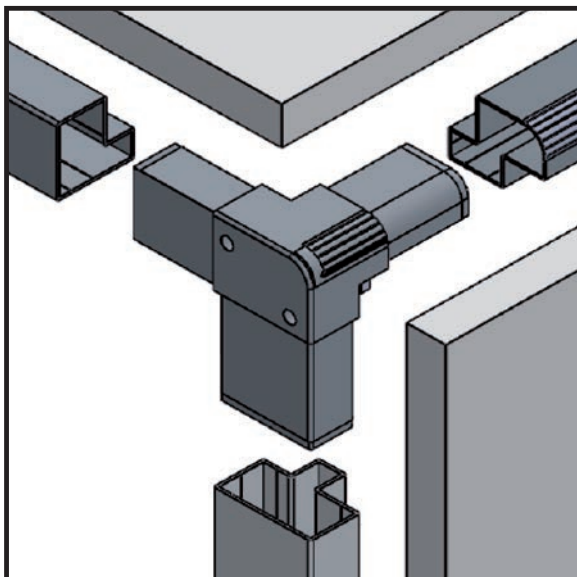

**TUV SUD – report test number MB747**

SPECIFICATIONS OF THE CASING ACCORDING TO <b>UNI-EN 1886</b>	
• casing strength	<b>D1</b>
• casing air leakage at -400 Pa	<b>L3</b>
• casing air leakage at +400 Pa	<b>L3</b>
• filter bypass leakage (at + and - 400 Pa)	<b>G1 – F9</b>
• thermal transmittance	<b>T2</b>
• thermal bridging factor	<b>TB3</b>

POLYURETHANE INSULATION SOUND ATTENUATION	
Frequency Hz	50 mm thick panels with polyurethane
125	dB 7
250	dB 8
500	dB 12
1K	dB 13
2K	dB 14
4K	dB 26
8K	dB 32

**TUV SUD – report test number MB748**

SPECIFICATIONS OF THE CASING ACCORDING TO <b>UNI-EN 1886</b>	
• casing strength	<b>D1</b>
• casing air leakage at -400 Pa	<b>L3</b>
• casing air leakage at +400 Pa	<b>L3</b>
• filter bypass leakage: + 400 Pa = <b>G1 – F9</b> / - 400 Pa = <b>G1 – F8</b>	
• thermal transmittance	<b>T3</b>
• thermal bridging factor	<b>TB3</b>

MINERAL WOOL INSULATION SOUND ATTENUATION	
Frequency Hz	50 mm thick panels with mineral wool
125	dB 11
250	dB 11
500	dB 16
1K	dB 20
2K	dB 20
4K	dB 25
8K	dB 28

The air intake may be on the front across the entire section, or alternatively partially, on the sides, the top or bottom.

The opening can be fitted with a damper positioned outside or inside the unit and/or vibration-damping joints.

In outdoor installations, the rear or side direct air intake openings can also be fitted with weather louver and bird screen.

## Mixing boxes

Featuring openings arranged in various positions as described above, fitted with dampers positioned outside or inside the unit and/or vibration-damping joints.



### Dampers

Counter-rotating louvers with connection flanges, available in the following versions:

- galvanised plate or aluminium with louvers connected by metal levers
- aluminium with louvers connected by plastic cogs
- aluminium with aerodynamic louvers and sealing gasket

The dampers always come with shafts for control levers, servo control or manual control.

### Grills

The direct intake openings or dampers on the units installed outdoors can be fitted with an aluminium or galvanised steel grill with fixed horizontal louvers to protect against the weather, plus bird screen.

### Vibration-damping joints

Built using galvanised plate section bars forming the connection flanges, joined at the corners with perforated brackets, these are made from special fabric treated to be flame retardant, washable and rot-resistant.

## Sections with three dampers

Sections fitted with three dampers, respectively for the discharge, recirculation and intake of fresh outside air. The discharge and outside air intake dampers can be installed outside or inside the unit, at the top (vertical air flows) or alternatively on the sides, either on the same side or on opposing sides (horizontal air flows).

The ambient air recirculation damper is always positioned inside, between the other two dampers. In installations with air handling units located outdoors and fitted with weather canopy, the discharge and direct air intake openings are located on the sides, and can be fitted with weather louver and bird screen.

This section is normally used in systems with variable occupancy, allowing the quantity of fresh air intake to be adjusted in proportion to actual requirements. The three dampers can also be adjusted to allow freecooling when cooling is required in mid-seasons due to high inside thermal loads.

The heat recovery sections can be used with two types of heat exchanger:

- **cross flow plate heat exchanger.**
- **heat wheel with opposing air flows.**
- **static with finned coils.**

### Plate heat exchangers

Supplied as standard in the aluminium version, also available in the protected version with acrylic treatment when used in aggressive atmospheres.

The section housing the exchanger can operate as a chamber with three dampers, including, alongside of the heat recovery unit, a recirculation damper positioned is described in the following diagrams.

The recovery unit can also be equipped with a by-pass damper to allow free-cooling operation, always according to the Ecodesign Directive.

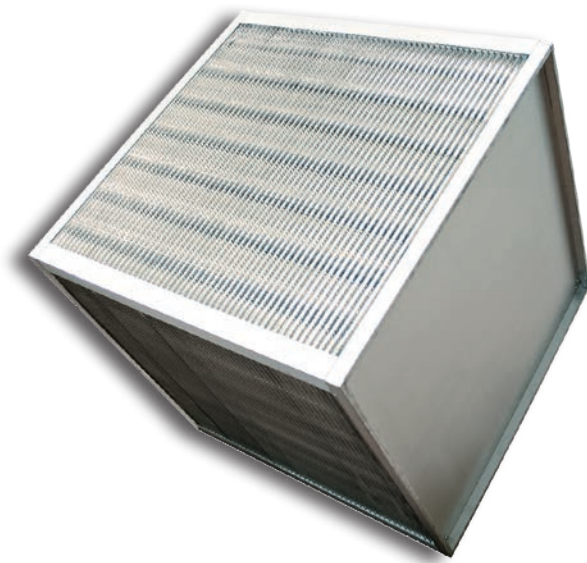

### Heat wheels

These are made up of a cylindrical rotor containing thousands of channels with a large surface area, a galvanised steel support frame complete with brush gaskets, and an actuator system consisting of an electric motor fitted, based on requirements, with a speed controller and control panel.

Heat exchange occurs by accumulating heat in the wheel, which then transfers it, when rotating, from one flow of air to the other.

The cylindrical rotor, in the standard version, is made entirely from aluminium, however it can also be chosen, using the calculation program, in the version with hygroscopic treatment for the purpose of increasing the efficiency of the device to exchange both heat and moisture between the two flows.



### Static recovery units with finned coils

They are designed by inserting renewal air into the aeraulic circuits and water in the expulsion circuit of the finned heat exchange coils, among which it is made to circulate by means of a special hydraulic system, to transfer heat between the two flows. Although this system does not achieve the high performance levels of the previous systems described, it is always used in all installations that strictly require no risk of pollution between the two flows due to system leakage.

Different types of filtering elements can be used in the filtration sections, classified according to their retaining and separation feature of particles and/or dust in the air that passes through them. The normal filters efficiency is in compliance with the mandatory standard according to the EN 779:2012 Regulation for the medium and high efficiencies and to the EN 1822:2009 Regulation for the absolute filters. The activated electrostatic filters are in compliance with the filtering efficiency UNI 11254:2007 Regulation.

### Synthetic corrugated filters



Class G4 filters (low efficiency) and class M6 (average efficiency), 48 and 98 mm thick, inserted on guides for removal from the side.

The filtering media is made from synthetic fibre, housed in a galvanised plate frame with welded galvanised wire protection mesh.

These can also be used as pre-filters for other higher efficiency filters; in this case, assembly is performed using special frames with fastening clips and removal from the front.

The filters are partially regenerable.

### Metal corrugated filters

Class G2 filters (low efficiency), 48 and 98 mm thick, with a similar construction to the model described above, however with filtering media made from aluminium mesh.

Normally used as pre-filters on the outside air intake in units installed in humid and foggy climates.

The filters are highly regenerable.

### Roll filters

Automatic roll filters with class G4 synthetic fibre media (low efficiency).

Complete with electric gear motor, differential pressure switch to automatically advance the dirty filter media, limit switch to signal the depleted filter media and electrical control panel.

Can be selected starting from size 175-125.

### Non-rigid bag filters

Filters with sewn fibreglass bags, available in class F6 (average efficiency 70%), F8 (average efficiency 92%) and F9 (average efficiency 95%), 535 mm in length, inserted in a special frame with sealing gasket and fastening clips, designed for removal from the front.

The filters are not regenerable.



### Rigid bag filters

Polyhedral rigid bag filters with pleated fibreglass paper media, available in class F6, F8 or F9, 290 mm in length, with plastic supports, inserted in a special frame with sealing gasket and fastening clips, designed for removal from the front.

The filters are not regenerable, and are completely incineratable.



### Absolute filters



Class H13 (efficiency 99.95%) or class H14 (efficiency 99.995%) filters, pleated glass paper media housed in a treated wooden frame, thermoplastic sealant and elastomer gasket, designed to be fitted in a special metal frame fixed by tension rods, with removal from the front.

These filters are normally positioned downstream from the supply fan in the air handling unit, and always represent the final treatment before the air is delivered into the environment.

The filters are not regenerable.

### Activated carbon filters

The activated carbon filters are available in two versions:

- polyhedral with dimensions and assembly frame similar to the rigid bag filters
- cylindrical cartridge filters to be fitted, with sealing gasket, on a special metallic frame with bayonet fastening.

The polyhedral filters, class F7 (average efficiency 80-85%) are suitable for both filtration and deodorisation, and always require minimum class G4 pre-filtration.

They are not regenerable.



### Crystall electrostatic filters

Modular cell aluminum electrostatic filter consisting of two separate and distinct sections, one of which is active (polarisation section), integral with the supporting structure, and the one being passive with induced anode (collection section), which can be removed for maintenance purposes.

**B-PE (≥ 95%) Filtration Efficiency**, supplied with high voltage power board inclusive of signaling led, power-ON/OFF switch and SPDT (Single pole double through) free contact useful to monitor the correct remote functioning.

The advantages of this solution, **which we designed and patented**, can be summarised as:

- High efficiency at clean filter (>97%)
- With low load drop (<30 Pa) even with a dirty filter with consequent energy savings
- Tested anti-bacterial action
- Continuous performance over time
- Simple and economic maintenance (total regenerability with simple washing)
- Ecologically sustainable solution
- Certified according to UNI 11254:2007



The following **humidification systems** can be used:

- **wick** (100 or 200 mm thick) with:
  - **once-through water**
  - **recirculated water with external pump** (up to size 250-175) with connections
  - **recirculated water with internal pump** with integral water circuit
- self-cleaning **spray nozzles** with:
  - single rack for **once-through water**
  - single rack with **recirculating pump**
  - double rack **with recirculating pump**
- **atomised water** with:
  - **compressed air**
  - **Humifog system**
- **steam** with:
  - centralised **supply**
  - **stand-alone** immersed electrode **humidifier**

Demineralised water must always be used.

The **droplet separators** can be made:

- entirely from galvanised plate, from aluminium or from stainless steel
- with a galvanised, aluminium or a stainless steel frame and PVC separator elements

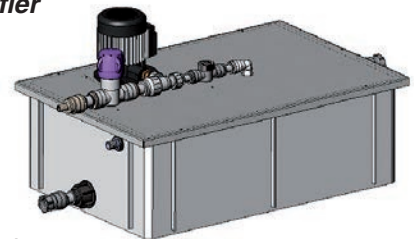

The **water collection trays** can be made from galvanised or stainless steel and are fitted with all the required threaded connections.

Upon request the access doors on the sections with nozzles can be fitted with inspection windows.

### Wick humidifier with once-through water

Adiabatic humidification using treated paper wetted media with a honeycomb structure, 100 and 200 mm thick, supplied with once-through water, complete with galvanised plate or AISI 304 stainless steel tray, droplet separator and threaded fittings for the water supply and drain.

### Wick humidifier with recirculated water

Humidifier as described above, fitted with recirculating water pump, complete with stainless steel strainer, refill float valve, flow adjustment valve, droplet separator and tray with threaded fittings for refill, overflow and drain.

EFFICIENCY AND WATER CONSUMPTION OF WICK HUMIDIFIERS

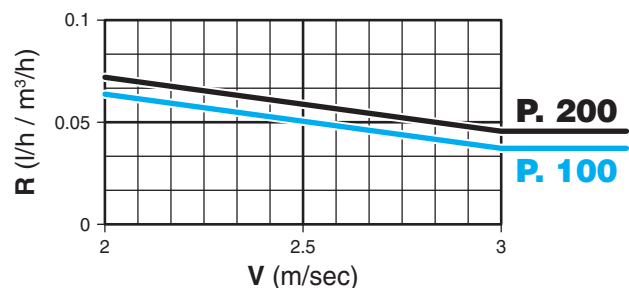
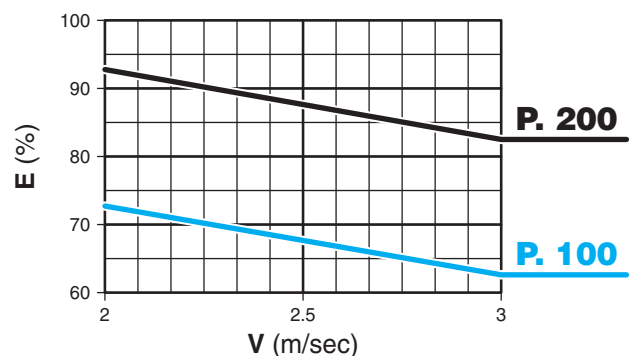

**E** = Saturation efficiency  
**R** = Water consumption ratio:  $R \times m^3/h = l/h$   
**V** = Air speed



### ***Spray nozzles with once-through water***

Double chamber humidifier with single rack of self-cleaning PVC atomising nozzles, in counterflow direction to the air, galvanised or stainless steel plate tray, droplet separator and threaded supply and drain fittings.

### ***Spray nozzles with recirculated water***

Double chamber humidifier with optional second access door, one or two racks (air washer) of self-cleaning PVC atomising nozzles, arranged both the same direction as the air and in counterflow, galvanised or stainless steel plate tray, flow straightener and splash at the inlet and droplet separator at the outlet, recirculating pump with stainless steel strainer, refill float valve, flow adjustment valve and threaded supply, drain and overflow fittings.

### ***Atomised water with compressed air***

Made up of a rack of self-cleaning AISI 316 stainless steel atomising nozzles in counterflow direction to the air, on-off or modulating control cabinet, droplet separator and tray.

### ***Atomised water with Humifog Carel system***

Made up of a rack of self-cleaning AISI 316 stainless steel atomising nozzles in the same direction as the air flow, housed in a stainless steel frame, control cabinet with motor-driven pump to pressurise the water, and tray.



### ***Centralised steam***

Made up of one or more stainless steel linear steam distributors, sized for the required flow-rate, fitted with condensate recovery hose, complete with droplet separator and tray.

### ***Steam from stand-alone immersed electrode humidifier***

Made from stainless steel steam distributor pipes with condensate recovery, immersed electrode steam generator with production proportional to requirements, complete with modulating electronic controller accepting a proportional signal from an external controller (supplied upon request) and power circuit.

The section is complete with droplet separator and tray.

The heat exchange sections contain the coils that can operate:

- with hot, chilled or superheated water
- with steam
- with refrigerants in expansion or condensation
- electrically

### Hot or chilled water coils

Made from finned copper tubes with spacer collars, steel or copper manifolds with threaded fittings and air vent and drain screws, galvanised plate frame.

The finned heat exchanger can be arranged in steps of 2 - 2.5 - 3 and 4 mm, and made from the following materials:

- aluminium
- painted aluminium
- copper
- tinned copper

The copper tubes have a diameter of 5/8" (16.45 x 0.4 mm) and come in the following shapes:

- P60 = 60 x 30 mm
- P40 = 40 x 30 mm
- P30 = 30 x 30 mm with 1 to 12 rows.

In some cases, different shapes are available, with 1/2" or 30 x 30 mm copper tubes.

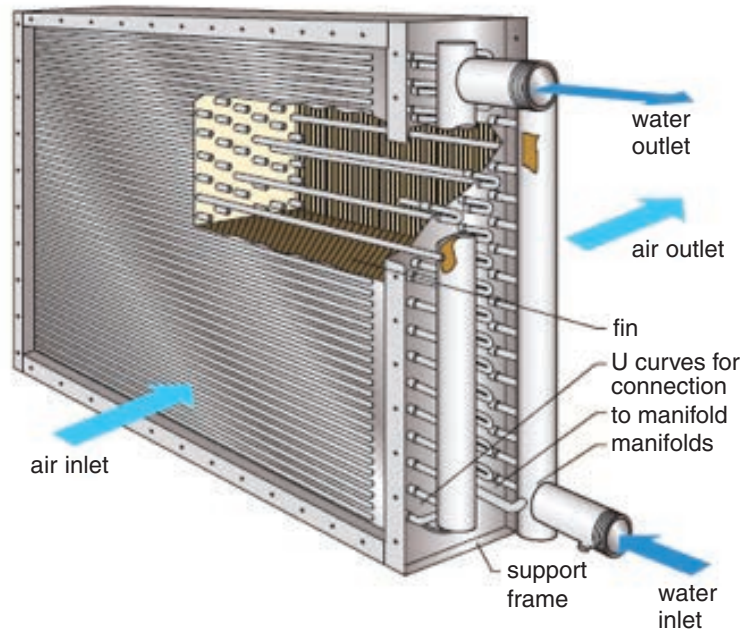

### Superheated water or steam coils

These can be made from 5/8" copper tubes, selected, in the calculation program, up to 0.75 mm thick for superheated water, or alternatively with steel tubes for steam.

The other features concerning the shape and the finned heat exchanger are similar to those previously described for hot or chilled water.

### Refrigerant coils

These are designed for expansion or condensation, with the same constructional characteristics as regards the tubes, the shapes and the finned heat exchanger as the hot or chilled water coils described previously.

The manifolds are made from copper with smooth welded fittings, while the expansion coils come with a brass distributor on the gas inlet side.

### Electric heaters

The electric coils are made from steel pipe immersion heaters with continuous spiral fins, each fitted with ceramic isolators at the heads, and connected together by brass plates.

The frame is made from galvanised plate, with perimeter fastening flanges and junction boxes at the side with cable glands and access openings to the connections.

Available for single-phase or three-phase power supply.



The fan sections can consist of different types of fans, which must be selected and sized based on the flow-rate, the static pressure, the noise generated and the efficiency.

In general, all the fan assemblies are fitted on a galvanised steel support structure, in turn fixed via elastomer vibration damping joints to a second base structure secured to the load-bearing frame of the casing.

All the fan outlets are joined to the panels via vibration damping joints, the access doors are always fitted with safety micro-switched and can, upon request, have inspection windows.

The transmission is made from a number of suitably sized V-belts according to the power transferred, and the pulleys are always fitted with Taperlock bushes.

The motors are Unel Mec brand with class F insulation, IP 55 protection and class IE3 energy fitted on slides or alternatively, for the plug fans, directly coupled to the rotor and suitable for inverter drive.

Motors with ratings higher than 7.5 kW must always feature star-delta starting.



### **Forward curved centrifugal fans**

Dual intake with galvanised steel screw and impeller, dynamically and statically balanced, fitted on steel shafts supported by pre-lubricated sealed bearings, ideal for low and medium pressure.

### **Backward inclined centrifugal fans**

Dual intake with galvanised steel chassis and screw, welded and painted steel impeller (polyamide for the smaller sizes), dynamically and statically balanced, fitted on steel shafts supported by pre-lubricated conical bearings, suitable for systems with medium and high static pressure that require good efficiency.

### **Backward inclined centrifugal fans with airfoil blades**

Dual intake with galvanised steel frame and screw, welded and painted steel impeller, dynamically and statically balanced, fitted on steel shafts supported by bearings on cast-iron supports with lubricator, especially suitable when high efficiency is required with high static pressure.

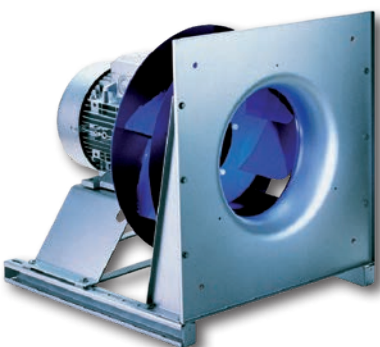

### **Plug fans**

Single intake with backward inclined impeller and directly coupled motor suitable for inverter drive.

The casing of the section, replacing the fan screw, is always in positive pressure. Therefore, to ensure the seal, all the panelling is sealed on the inside and the access doors are totally removable and fastened, using reinforcement bars, by screw knobs.

Made from a series of 100 mm thick layers of sized mineral wool, arranged in the direction of air flow, spaced 100 mm apart, normally positioned at the inlet and/or outlet of the handling unit to reduce the noise generated by the fans.

The graph indicates the attenuation value in dB for the standard silencers (available in the three lengths, 900 - 1200 and 1500 mm) to be subtracted from the noise generated by the chosen fan and indicated by the selection program, thus calculating the overall noise transmitted in the air ducts connected to the unit.

The silencer should be positioned a minimum distance apart from the preceding or following equal to around the net height inside the unit and, if installed after the fan, the latter must be fitted with a flow equalizer on the outlet.

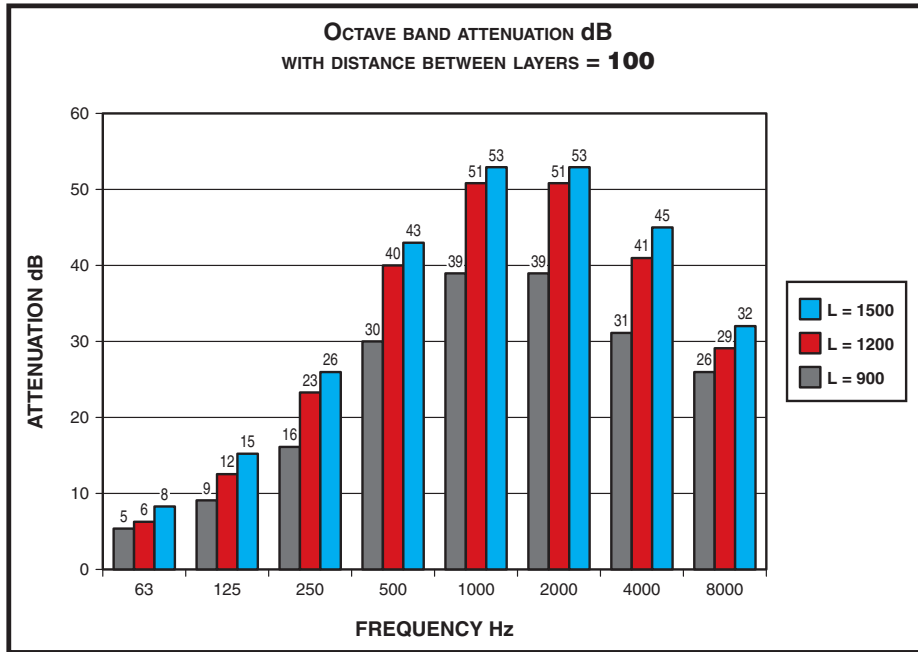

### Sections with germicidal tubes

Designed for **localised irradiation** on components, such as filters and coils, and also as **tunnels** to purify the air with UV-C rays at 200-280 nm.

The ultraviolet rays within these wavelengths mainly have a germicidal and bactericidal action against microorganisms; these are found everywhere and show a very high metabolic rate, especially in hot-humid environments with static air, mould fungi multiply exponentially.

The tubes used are the latest with a medium-low pressure rate and generate shortwave radiation derived from mercury vapor discharge.

The germicidal effect of the ultraviolet energy can ensure certain disinfection with low intensity for a long time or with high intensity for a short time, as in the case of air passage tunnels. For bactericidal disinfection of the air, low exposure intensity is generally required, which is much lower than that required, for example, to protect products from mould.

It must also be made clear that the disinfected air does not in itself have a disinfectant effect and that the UV rays can not be regarded as sterilising since they only perform an antiseptic action.



The **Titan** air handling units can be supplied complete with thermoregulation, designed and manufactured on a standard basis or according to technical specifications of the Customer.

All regulation units are provided with already made connections, except for the hydraulic ones and therefore the valves are always supplied separately with own packaging.

The electrical panels are normally mounted on the one side of the unit but they can also be provided separately with a terminal block mounted as support.

The management software comes with easy controls that can also be used for remote installation and set up to interface local monitoring systems, such as Modbus RTU, LonWorks, Konnex. Ethernet and BACnet.

The wiring and the evaluation test is always set within our factory, the eventual activation on site is always quoted separately on request.

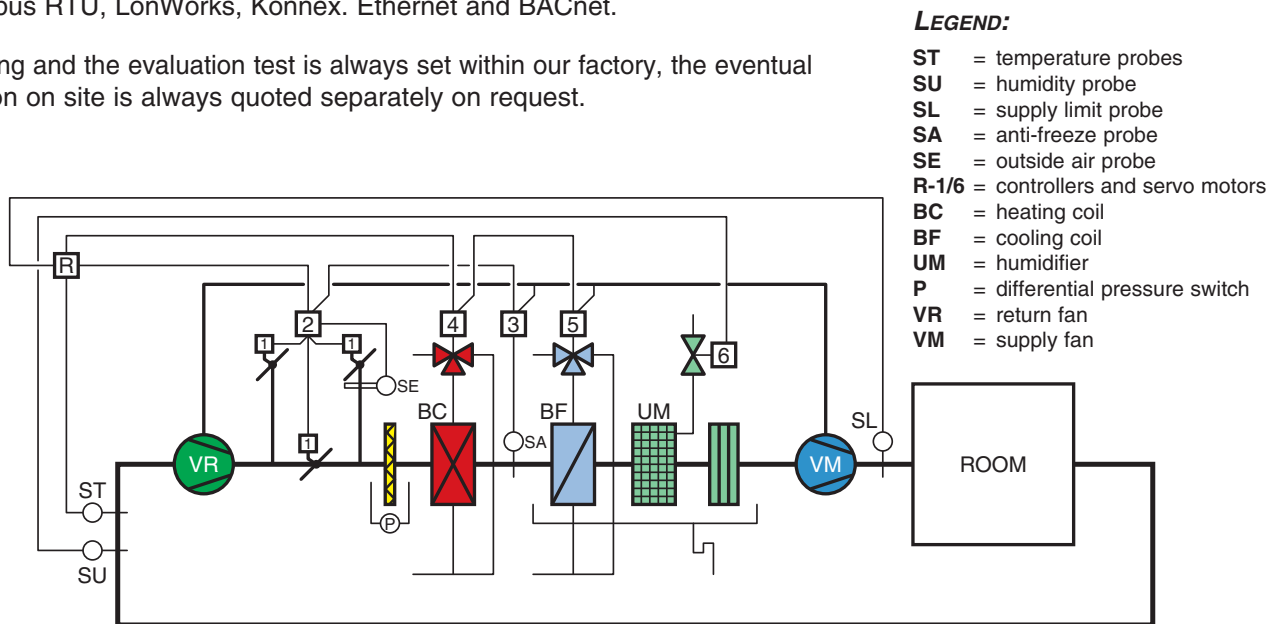

## Accessories

The following accessories can be supplied upon request:



- **Weather canopy** for outdoor installation, made from painted galvanised steel or aluminium.
- **Utility compartment** containing the temperature control devices, normally installed on the opposite side to the filter and fan section inspection openings, covering the same length as the entire unit or limited to the air handling section, depth around 700 – 1000 o 1300 mm, complete with access doors.
- **Lights** inside the sections fitted with access door plus inspection window, wired to the switch on the outside.
- Differential air pressure gauge to signal dirty filters.
- **Inverters** to power and control electric motors, supplied separately in their own packaging or wired if the thermoregulation is supplied. The ventilation motor units fitted with an electronic motor (Brushless) are always supplied with a wired controller on board-machine.
- **Protective guard** on the transmission.
- **Safety grid** for the openings of the fan section.

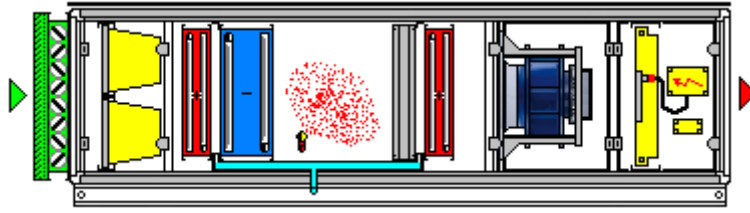

Outdoor monoblock unit with protective cover, rain protection grill with bird guards, on-off damper, F6 pre-filters, treatment section with pre-heating, cooling and dehumidification coil, steam and post-heating coil. Motor fan section with plug-fan unit equipped with electronic brushless motor with controller and filtration with SABIANA Crystall electrical filters.

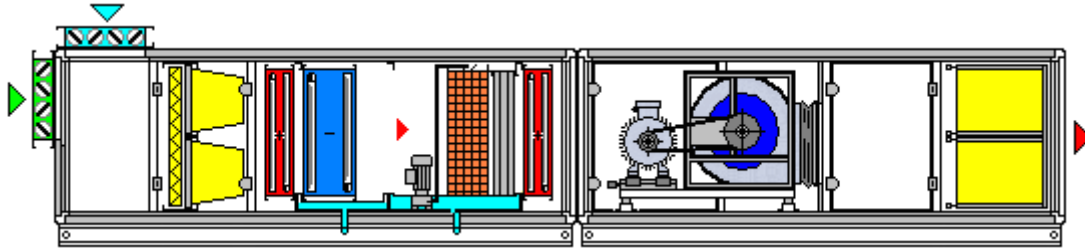

Double deck unit with mixing chamber, G4+F9 pre-filters, treatment section with pre-heating, cooling and dehumidification coil, honeycomb pack humidifier with recirculation and post-heating coil. Motor-fan section with centrifugal transmission fan designed to be inverter-controlled (Ecodesign directive requirement) and H13 absolute filtration.

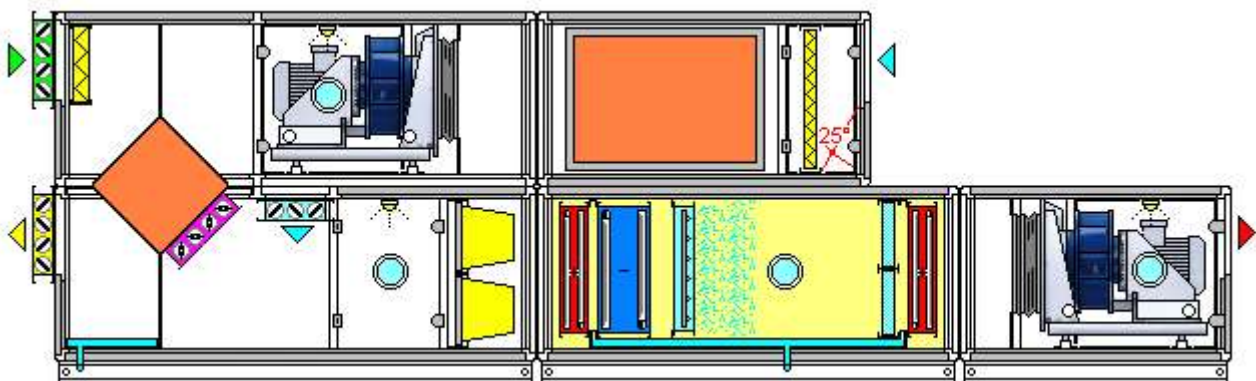

Double deck unit with static heat recovery unit having at least 67% efficiency and equipped with a free-cooling damper (Ecodesign directive requirements) with recirculation louvre, M6 filters at the recirculation and fresh air inlet, F9 filters, air handling section with stainless steel panels inside, treatment section with pre-heating, cooling and dehumidification coil, spray nozzle humidifier with droplet separator and post-heating coil. Fan sections with inverter-controlled plug-fan units (Ecodesign directive requirements) an inlet silencer, lights and inspection inlets.

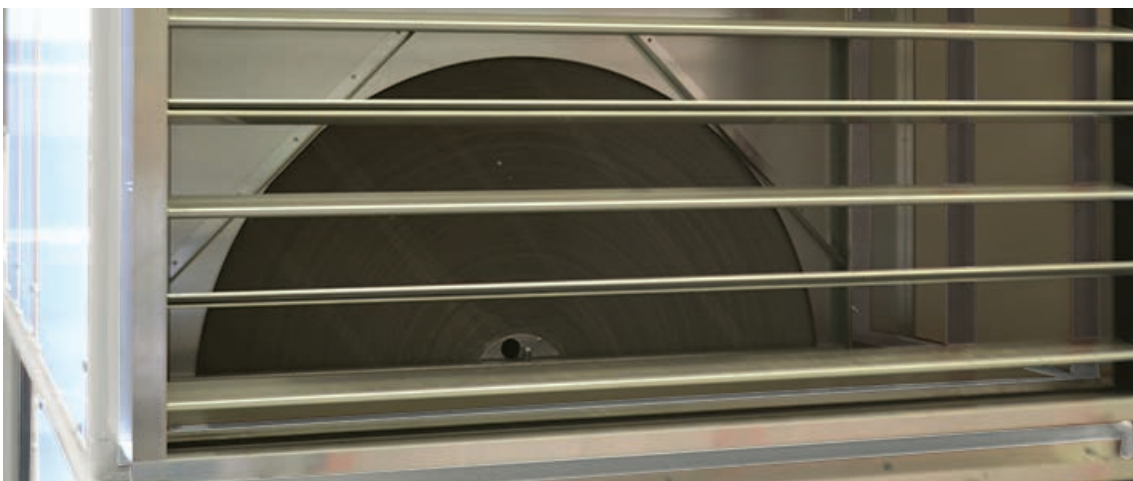



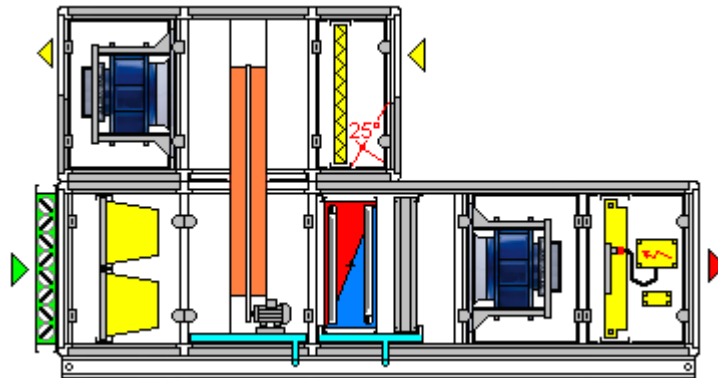
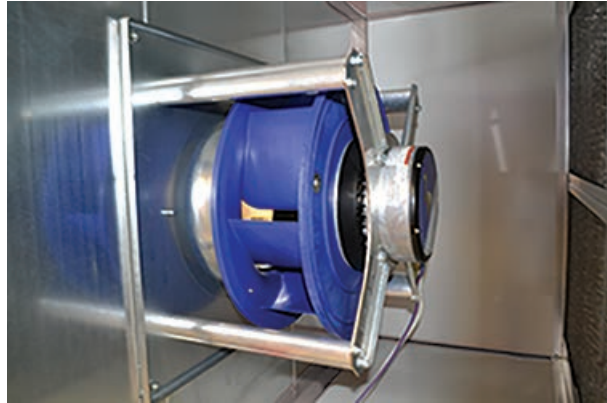

fig. A

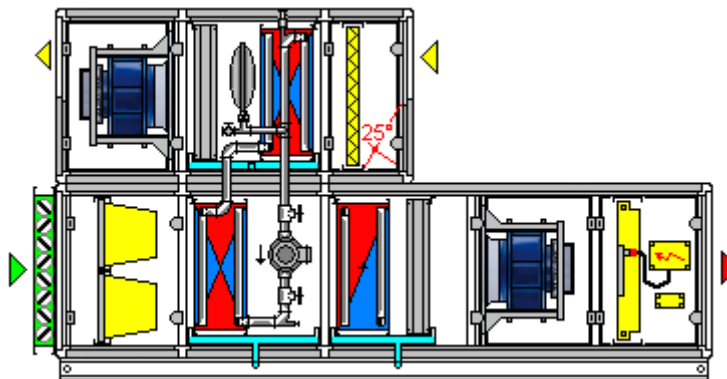
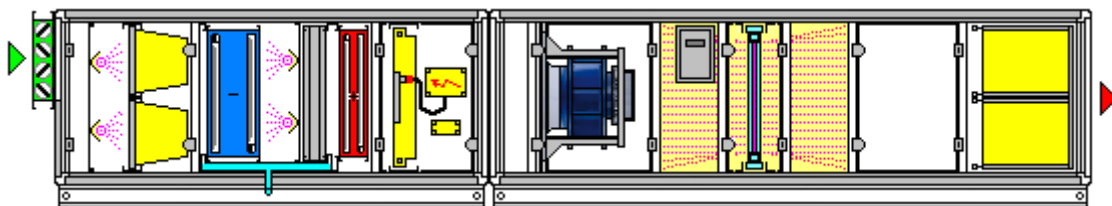

fig. B

Double deck unit with G4 filter on the exhaust air and M6 pre-filter on the fresh air.  
Rotary recovery unit (fig.A) and recovery coils (fig.B). Air handling with a single heat/cool coil with droplet separator.  
Motor fan section with plug-fan unit fitted with a brushless electronic motor with controller and **SABIANA Crystal electrostatic filters**.



Double deck unit in line, fitted with localised germicidal sections at the M6 pre-filters and the cooling and dehumidification coil (humid zone), with **filtration SABIANA Crystal electrostatic filters**.

Fan unit with plug-fan assembly with brushless electronic motor with controller, germicidal tunnel and H13 absolute filter.

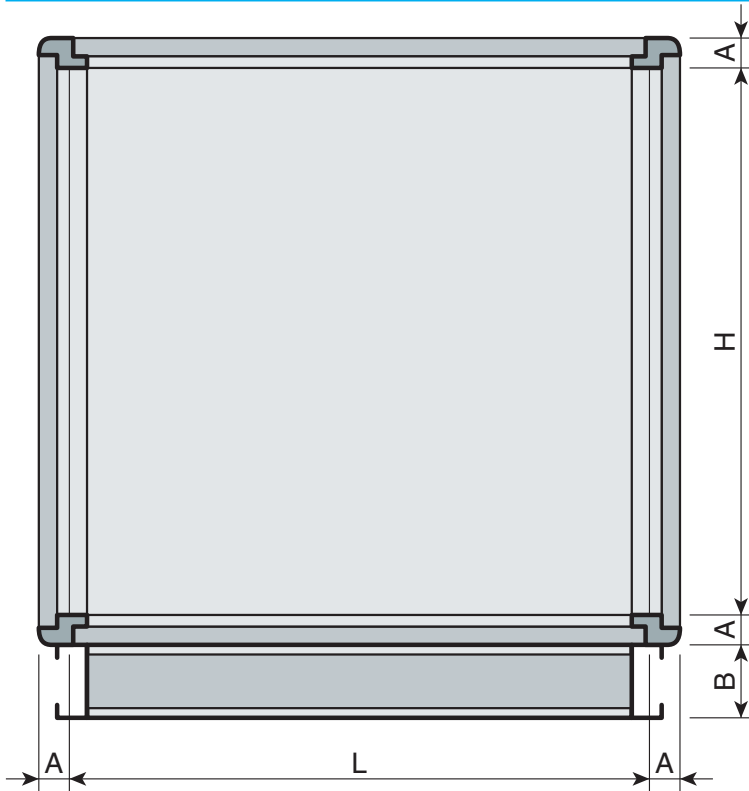

- **A = 50 mm** (corresponds to the thickness of the panels)
- Base:
  - **B = 80/100\*/120 mm**
  - \* = in alluminio estruso

*The lengths of the sections and the corresponding weights must be obtained from the selection software.*

Size	Measurement <b>L</b> (mm)	Measurement <b>H</b> (mm)
<b>100 - 75</b>	650,0	457,5
<b>125 - 75</b>	802,5	457,5
<b>100 - 100</b>	650,0	610,0
<b>125 - 100</b>	802,5	610,0
<b>150 - 100</b>	955,0	610,0
<b>175 - 100</b>	1107,5	610,0
<b>175 - 125</b>	1107,5	762,5
<b>200 - 125</b>	1260,0	762,5
<b>175 - 150</b>	1107,5	915,0
<b>200 - 150</b>	1260,0	915,0
<b>250 - 150</b>	1565,0	915,0
<b>250 - 175</b>	1565,0	1067,5
<b>250 - 200</b>	1565,0	1220,0
<b>300 - 200</b>	1870,0	1220,0
<b>300 - 250</b>	1870,0	1525,0
<b>350 - 250</b>	2175,0	1525,0
<b>400 - 250</b>	2480,0	1525,0
<b>400 - 300</b>	2480,0	1830,0
<b>450 - 300</b>	2785,0	1830,0
<b>500 - 300</b>	3090,0	1830,0
<b>550 - 350</b>	3395,0	2135,0
<b>650 - 350</b>	4005,0	2135,0
<b>650 - 400</b>	4005,0	2440,0





IONet, the association of the world's first class certification bodies, is the largest provider of management System Certification in the world.  
IONet is composed of more than 30 bodies and counts over 150 subsidiaries all over the globe.

CERTIFICATO n. **0545/7**  
CERTIFICATE No. \_\_\_\_\_

SI CERTIFICA CHE IL SISTEMA DI GESTIONE PER LA QUALITÀ DI  
WE HEREBY CERTIFY THAT THE QUALITY MANAGEMENT SYSTEM OPERATED BY

### SABIANA S.p.A.

Sede e Unità Operativa: Via Piave, 53 - 20011 Corbetta (MI)  
Direzione e uffici amministrativi, progettazione, produzione di apparecchiature per il riscaldamento e il condizionamento dell'aria (aerotermi, termostrisce radianti, unità trattamento aria) e canne fumarie.

Unità Operativa: Via Virgilio, 2 - 20013 Magenta (MI)  
Produzione di ventilconvettori, magazzino e logistica

Italia

È CONFORME ALLA NORMA / IS IN COMPLIANCE WITH THE STANDARD

### UNI EN ISO 9001:2015

Sistema di Gestione per la Qualità / Quality Management System

PER LE SEGUENTI ATTIVITÀ / FOR THE FOLLOWING ACTIVITIES

EA: 18

Progettazione, produzione e assistenza di apparecchiature per il riscaldamento e il condizionamento dell'aria (aerotermi, termostrisce radianti, ventilconvettori e unità trattamento aria) e canne fumarie.

*Design, production and service of heating and air conditioning equipment (unit heaters, radiant panels, fan coil units and air handling units) and chimneys.*

Riferirsi alla documentazione del Sistema di Gestione per la Qualità aziendale per l'applicabilità dei requisiti della norma di riferimento.  
Refer to the documentation of the Quality Management System for details of application to reference standard requirements.

Il presente certificato è soggetto al rispetto del documento ICIM "Regolamento per la certificazione dei sistemi di gestione" e al relativo Schema specifico.  
The use and the validity of this certificate shall satisfy the requirements of the ICIM document "Rules for the certification of company management systems" and specific Scheme.

Per informazioni parziali e aggiornate circa eventuali variazioni intervenute nello stato della certificazione di cui al presente certificato, si prega di contattare il n° telefonico +39 02 722341 o indirizzo e-mail info@icim.it.  
For timely and updated information about any changes in the certification status referred to in this certificate, please contact the number +39 02 722341 or email address info@icim.it.

Data emissione  
First issue  
10/06/1996

Emissione corrente  
Current issue  
1C/04/2018

Data di scadenza  
Expiring date  
09/04/2021

ICIM S.p.A.  
Piazza Don Enrico Mattei, 75 - 20090 Sesto San Giovanni (MI)  
www.icim.it



SC08 N° 004 A PRD N° 004 B  
SC09 N° 005 D PRS N° 002 C  
SC10 N° 005 M ISP N° 046 E  
SC11 N° 006 F ITS N° 003 D  
SC12 N° 008 G EMS N° 001 P

Membro degli Accordi di Mutuo Riconoscimento EA, IAF e ILAC  
Signatory of EA, IAF and ILAC Mutual Recognition Agreements



www.cisq.com

CISQ è la Federazione Italiana di Organismi di Certificazione dei sistemi di gestione aziendale.  
CISQ is the Italian Federation of management system Certification Bodies.

0449ICIM\_03\_IT

*The descriptions and illustrations provided in this publication are not binding: Sabiana reserves the right, whilst maintaining the essential characteristics of the types described and illustrated, to make, at any time, without the requirement to promptly update this piece of literature, any changes that it considers useful for the purpose of improvement or for any other manufacturing or commercial requirements.*

**Air Conditioning**  
Titan Air Handling Units

UTA - EX - 04/18  
Cod. 99A4002100 B/04/18

